

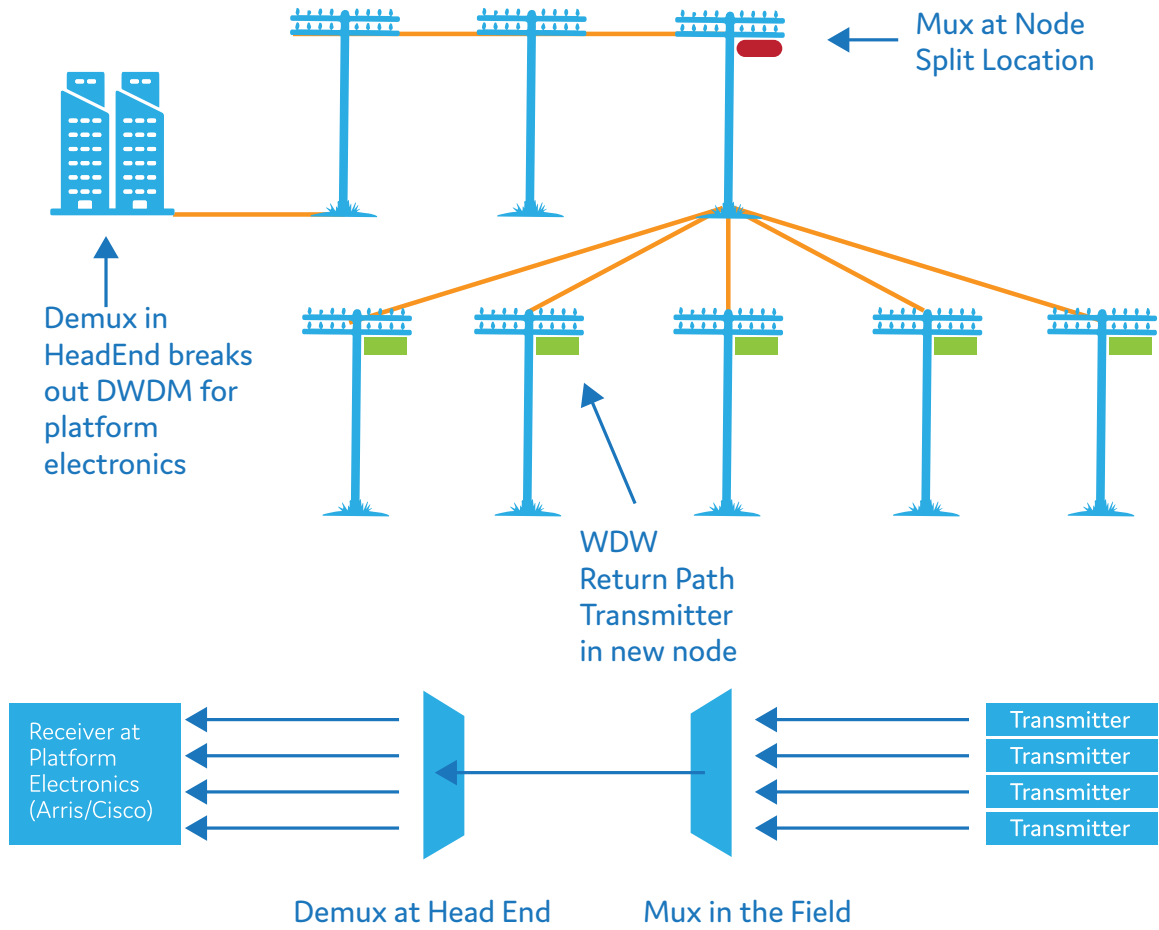

SCTE

Connectivity
with built in
cost and
space saving
efficiency.

ProLabs
Unlock your connectivity



We continually strive to provide innovative solutions that increase network performance.

Slim Mux/Demux

½ Wide LGX form factor
4, 8 Channel Mux/Demux options
DWDM CWDM Options
Telcordia Compliant
LC Adapters
5.2"H x .6"W x 3"D
Mounts in Standard and
½ Wide LGX Chassis



Compact Mux/Demux

Compact ABS Box Form Factor
4, 8 Channel Mux/Demux options
DWDM CWDM Options
Telcordia Compliant
90mm x 120mm x 8mm
2M 900micron fiber pigtailed
Ideal for splice cases and
other field applications



Field Mux

Add/Drop Mux
Stainless Steel Housing
DWDM CWDM Options
Telcordia Compliant
35mmL x 5.5mmΦ
2M Fiber Pigtailed
Ideal for splice case single
channel add or drop



We are innovators of network solutions,
focused on delivering compatibility tailored to your
connectivity needs.

Our knowledge of optical networking
technology enables us to be your single source for
optical transport and connectivity solutions from
100Mb to 100G.

We also provide the optical connectivity
expertise that is compatible with and enhances
your switching and transport equipment.

Visit www.prolabs.com for more
connectivity solutions.